

8 7 6 5 4 3 2 1

D
C
B
A

D
C
B
A

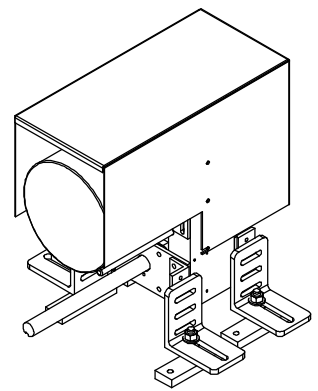
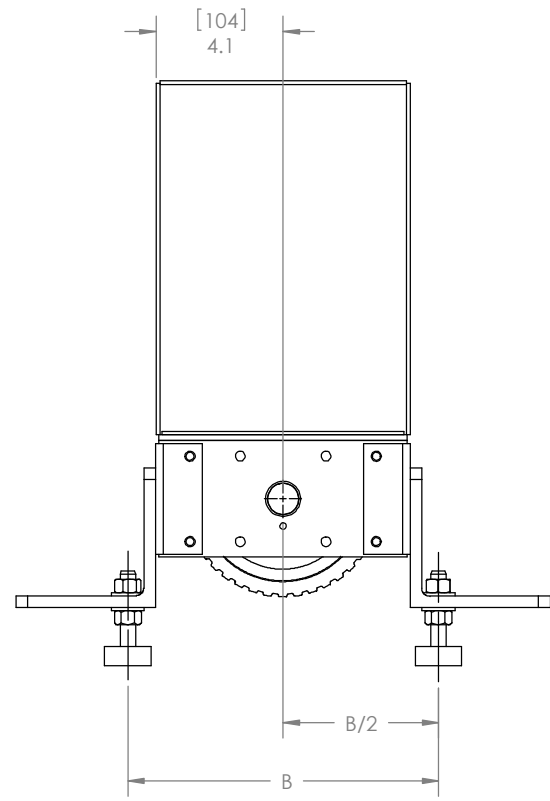
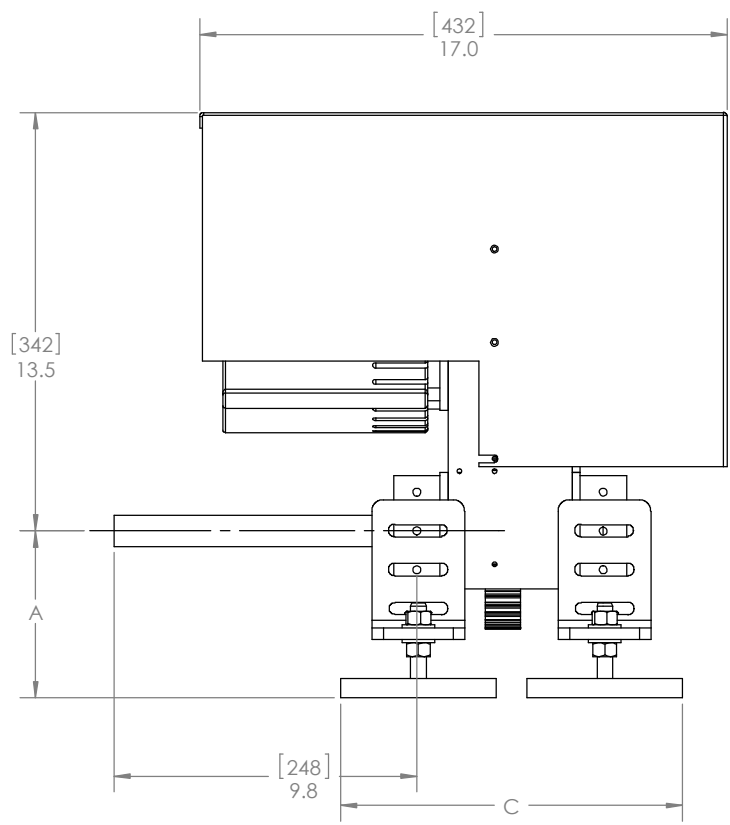

Note:
 A.) Distance from shaft to the bottom of foot Max Below Shaft: 5.981 [152], Max Above Shaft: 7.625 [194]
 B.) Center line of foot to center line of foot Max (With Spacers): 18.30 [465], Min: 9.80 [245]
 C.) Distance from outside of foot to outside of foot Max: 14.5 [368], Min 10.5 [267]

APPROVED BY: SCOTT
 DRAWN BY: TKH
 DATE: 03-15-11

PROPRIETARY AND CONFIDENTIAL
 THE INFORMATION CONTAINED IN THIS DRAWING IS THE SOLE PROPERTY OF MELROSE METALWORKS. ANY REPRODUCTION IN PART OR AS A WHOLE WITHOUT THE WRITTEN PERMISSION OF MELROSE METALWORKS IS PROHIBITED.

MATERIAL: AS NOTED IN PART
 FINISH: DO NOT SCALE DRAWING

UNLESS OTHERWISE SPECIFIED:
 DIMENSIONS ARE IN INCHES
 TOLERANCES:
 FRACTIONAL ±1/16
 ANGULAR: MACH ±1° BEND ±1°
 TWO PLACE DECIMAL ±.01
 THREE PLACE DECIMAL ±.005

ELECTRIC YACHT		
TITLE:		
QT 5.0-15.0		
SIZE	DWG. NO.	REV
B	100 IBL	1
SCALE: 1:4	WEIGHT:	SHEET 2 OF 2

8 7 6 5 4 3 2 1